

# Spectrex SharpEye™ 40/40C and 40/40D Series

Flame Detectors



**Legal notice**

The device described in this document is the property of Emerson.

No part of the hardware, software, or documentation may be reproduced, transmitted, transcribed, stored in a retrieval system, or translated into any language or computer language, in any form or by any means, without prior written permission from Emerson.

While great efforts have been made to ensure the accuracy and clarity of this document, Emerson assumes no liability resulting from any omissions in this document or from misuse of the information obtained herein. The information in this document has been carefully checked and is believed to be entirely reliable with all of the necessary information included. Emerson reserves the right to make changes to any products described herein to improve reliability, function, or design and reserves the right to revise this document and make changes from time to time in content hereof with no obligation to notify any persons of revisions or changes. Emerson does not assume any liability arising out of the application or any use of any product or circuit described herein; neither does it convey license under its patent rights or the rights of others.

**Warranty**

1. **Limited Warranty** . Subject to the limitations contained in Section 2 (Limitation of Remedy and Liability) herein, Seller warrants that (a) the licensed firmware embodied in the Goods will execute the programming instructions provided by Seller; (b) that the Goods manufactured by Seller will be free from defects in materials or workmanship under normal use and care; and (c) Services will be performed by trained personnel using proper equipment and instrumentation for the particular Service provided. The foregoing warranties will apply until the expiration of the applicable warranty period. Sensors and detectors are warranted against defective parts and workmanship for 36 months for SharpEye 40/40C models and 60 months for SharpEye 40/40D models from the date of purchase.

Products purchased by Seller from a third party for resale to Buyer (Resale Products) shall carry only the warranty extended by the original manufacturer. Buyer agrees that Seller has no liability for Resale Products beyond making a reasonable commercial effort to arrange for procurement and shipping of the Resale Products. If Buyer discovers any warranty defects and notifies Seller thereof in writing during the applicable warranty period, Seller shall, at its option, (i) correct any errors that are found by Seller in the firmware or Services; (ii) repair or replace FOB point of manufacture that portion of the Goods found by Seller to be defective; or (iii) refund the purchase price of the defective portion of the Goods/Services. All replacements or repairs necessitated by inadequate maintenance; normal wear and usage; unsuitable power sources or environmental conditions; accident; misuse; improper installation; modification; repair; use of unauthorized replacement parts; storage or handling; or any other cause not the fault of Seller, are not covered by this limited warranty and shall be replaced or repaired at Buyer's sole expense, and Seller shall not be obligated to pay any costs or charges incurred by Buyer or any other party except as may be agreed upon in writing in advance by Seller. All costs of dismantling, reinstallation, freight, and the time and expenses of Seller's personnel and representatives for site travel and diagnosis under this limited warranty clause shall be borne by Buyer unless accepted in writing by Seller. Goods repaired and parts replaced by Seller during the warranty period shall be in warranty for the remainder of the original warranty period or 90 days, whichever is longer. This limited warranty is the only warranty made by Seller and can be amended only in a writing signed by an authorized representative of Seller. The limited warranty herein ceases to be effective if Buyer fails to operate and use the Goods sold hereunder in a safe and reasonable manner and in accordance with any written instructions from the manufacturers. THE WARRANTIES AND REMEDIES SET FORTH ABOVE ARE EXCLUSIVE. THERE ARE NO REPRESENTATIONS OR WARRANTIES OF ANY KIND, EXPRESSED OR IMPLIED, AS TO MERCHANTABILITY, FITNESS FOR PARTICULAR PURPOSE, OR ANY OTHER MATTER WITH RESPECT TO ANY OF THE GOODS OR SERVICES.

2. **Limitation of Remedy and Liability** SELLER SHALL NOT BE LIABLE FOR DAMAGES CAUSED BY DELAY IN PERFORMANCE. THE REMEDIES OF BUYER SET FORTH IN THE AGREEMENT ARE EXCLUSIVE. IN NO EVENT, REGARDLESS OF THE FORM OF THE CLAIM OR CAUSE OF ACTION (WHETHER BASED IN CONTRACT INFRINGEMENT, NEGLIGENCE, STRICT LIABILITY, OTHER TORT, OR OTHERWISE), SHALL SELLER'S LIABILITY TO BUYER AND/OR BUYER'S CUSTOMERS EXCEED THE PRICE TO BUYER OF THE SPECIFIC GOODS MANUFACTURED OR SERVICES PROVIDED BY SELLER GIVING RISE TO THE CLAIM OR CAUSE OF ACTION. BUYER AGREES THAT IN NO EVENT SHALL SELLER'S LIABILITY TO BUYER AND/OR BUYER'S CUSTOMERS EXTEND TO INCLUDE INCIDENTAL, CONSEQUENTIAL, OR PUNITIVE DAMAGES. THE TERM "CONSEQUENTIAL DAMAGES" SHALL INCLUDE, BUT NOT BE LIMITED TO, LOSS OF ANTICIPATED PROFITS, REVENUE OR USE AND COSTS INCURRED INCLUDING WITHOUT LIMITATION FOR CAPITAL, FUEL AND POWER, AND CLAIMS OF BUYER'S CUSTOMERS.

**Technical support**

To get technical support for this product, contact your local Rosemount representative or the Rosemount Technical Support department at +1 866 347 3427 or [safety.csc@emerson.com](mailto:safety.csc@emerson.com)

**Abbreviations and acronyms**

Abbreviation or acronym	Definition
ATEX	Atmospheric explosives

Abbreviation or acronym	Definition
AWG	American wire gauge
BIT	Built-in test
EMC	Electromagnetic compatibility
EOL	End of line
FOV	Field of view
HART®	Highway addressable remote transducer - communication protocol
IAD	Immune at any distance
IECEX	International Electrotechnical Commission Explosion
IPA	Isopropyl alcohol
IR	Infrared
JP5	Type of jet fuel
Latching	Refers to relays remaining in the ON state even after the ON condition has been removed.
LED	Light emitting diode
LPG	Liquified petroleum gas
mA	Milliamps (0.001 amps)
Modbus®	Master-slave messaging structure
N.C.	Normally closed
N.O.	Normally open
N/A	Not applicable
NFPA	National Fire Protection Association
NPT	National pipe thread
RS485	Communication protocol allowing bi-directional communication
PN	Part number
SIL	Safety integrity level
UNC	Unified coarse thread
Vac	Volts alternating current
Vdc	Volts direct current



## Contents

<b>Chapter 1</b>	<b>Introduction.....</b>	<b>7</b>
	1.1 Product overview.....	7
	1.2 Models.....	7
<b>Chapter 2</b>	<b>Installation.....</b>	<b>11</b>
	2.1 Installation guidelines.....	11
	2.2 Preparation for use.....	11
	2.3 Attach detector to tilt mount.....	15
	2.4 Open the back cover.....	16
	2.5 Wire terminals and ground cable.....	16
	2.6 Install the protective cover.....	21
	2.7 Aim the detector.....	22
	2.8 Changing default detector settings .....	22
<b>Chapter 3</b>	<b>Operation.....</b>	<b>25</b>
	3.1 Power up the detector.....	25
	3.2 Testing procedures.....	25
<b>Chapter 4</b>	<b>Initial setup.....</b>	<b>27</b>
	4.1 Continuous feature test.....	27
	4.2 Response to fault indication.....	27
	4.3 Built-in-test (BIT).....	27
<b>Chapter 5</b>	<b>Maintenance.....</b>	<b>29</b>
	5.1 Keeping maintenance records.....	29
	5.2 Clean the detector.....	29
<b>Chapter 6</b>	<b>Troubleshooting.....</b>	<b>31</b>
	6.1 Light-emitting diode (LED) is off, fault relay is open, 0-20 mA shows 0 mA, analog voltage output is 0 V.....	31
	6.2 Light-emitting diode (LED) flashes yellow at 4 Hz, fault relay is open, 0-20 mA shows 1 mA.....	31
	6.3 Light-emitting diode (LED) flashes yellow at 4 Hz, relay is open, 0-20 mA shows 2 mA.....	31
	6.4 Light-emitting diode (LED) constantly red, alarm relay energized, 0-20 mA indicates alarm.....	32
	6.5 No HART® communication, 0-20 mA shows 0 mA.....	32
<b>Chapter 7</b>	<b>Specifications.....</b>	<b>33</b>
	7.1 Technical specifications.....	33
	7.2 Electrical specifications.....	38
	7.3 Mechanical specifications.....	39
<b>Appendix A</b>	<b>Reference data.....</b>	<b>41</b>
	A.1 Ordering information, specifications, and dimensional drawings.....	41

**Contents**  
December 2021

**Reference Manual**  
00909-0100-4975

---

	A.2 Product certifications and installation drawings.....	41
<b>Appendix B</b>	<b>FM fuel test responses .....</b>	<b>43</b>
<b>Appendix C</b>	<b>Immunity to false alarm sources.....</b>	<b>47</b>

# 1 Introduction

## 1.1 Product overview

The SharpEye 40/40 series is based on proven Spectrex technologies, including triple infrared (IR3) and ultraviolet infrared (UV/IR). The SharpEye 40/40 series features QuadSense™ technology, providing the fastest response to fire, longest distance detection, and revolutionary UV/IR technology, coupled with superior immunity to false alarms, functioning in harsh conditions with unparalleled reliability and durability.

The series is suited to meet the challenges of wide range of industrial and commercial applications with long distance and fast response detection, providing superior protection of high value property and personnel to keep a SharpEye on your safety.

Detection performance can be easily adapted to all environments, applications, and requirements, by changing the detector's configuration parameters. Adjusting these parameters, as well as performing other maintenance and monitoring tasks, is possible by means of RS-485-based Modbus® communication or HART® communication.

## 1.2 Models

The SharpEye 40/40 Flame Detectors are electro-optical devices designed to identify fire events, enabling alarm activation. The detectors are intended for indoor or outdoor use and can be used stand alone or connected to an alarm/automatic extinguishing system.

The SharpEye 40/40 series comprises the following detectors:

### SharpEye 40/40C-I

The SharpEye 40/40C-I, a multispectrum Quad-sense™ flame detector, detects hydrocarbon fuel and gas fires with enhanced performance, advanced long distance detection of hydrocarbon fires, fast detection in under five seconds, and strengthened reliability. The SharpEye 40/40C-I is based on proven triple infrared (IR3) technology, ensuring high sensitivity with superior immunity to false alarms.

### SharpEye 40/40C-M

The SharpEye 40/40C-M multispectrum Quad-sense IR flame detector is specifically designed for the detection of hydrocarbon and hydrogen flames with enhanced performance, advanced long distance detection of hydrogen and hydrocarbon fires, fast detection in under five seconds, and strengthened reliability. The SharpEye 40/40C-M is based on proven triple IR (IR3) technology, ensuring high sensitivity with superior immunity to false alarms.

### SharpEye 40/40C-LB

The SharpEye 40/40C-LB is a dual spectrum ultraviolet (UV)/IR flame detector, designed to provide fast detection in under five seconds of a range of fires, such as hydrocarbon-based fuel and gas, hydroxyl, hydrogen, metal, and inorganic.

#### SharpEye 40/40C-L4B

The SharpEye 40/40C-L4B is a dual spectrum UV/IR flame detector designed to provide fast detection in under five seconds of hydrocarbon-based fuel and gas fires.

#### SharpEye 40/40D-I

The SharpEye 40/40D-I, an ultra-fast multispectrum Quad-sense IR3 flame detector, provides superior, longest distance detection of hydrocarbon fires at up to 295.3 ft (90 m), exceptional ultra-fast detection in under 50 msec, and unparalleled reliability. The SharpEye 40/40D-I is based on proven Triple IR (IR3) technology, ensuring highest sensitivity with best immunity to false alarms.

#### SharpEye 40/40D-M

The SharpEye 40/40D-M is a multispectrum Quad-sense IR flame detector that provides superior, longest distance detection of hydrogen (at up to 164.0 ft (50 m)) and hydrocarbon fires (at up to 295.3 ft (90 m)), exceptional ultra-fast detection in under 50 msec, and unparalleled reliability. The SharpEye 40/40D-M is designed to deal with the challenges of invisible fires based on proven IR3 technology, ensuring highest sensitivity with best immunity to false alarms.

#### SharpEye 40/40D-LB

The SharpEye 40/40D-LB is an ultra-fast UV/IR flame detector, which is able to detect in under 20 msec and features a unique dual sensor with selectable UV and IR channels that can be used separately or combined. The detector is designed to detect a range of fires, such as hydrocarbon-based fuel and gas, hydroxyl, hydrogen, metal, and inorganic.

#### SharpEye 40/40D-L4B

The SharpEye 40/40D-L4B is an ultra-fast UV/IR flame detector that is able to detect in under 20 msec, and features a unique dual sensor with selectable UV and IR channels that can be used separately or combined. The detector is designed to detect hydrocarbon-based fuel and gas fires.

**Table 1-1: SharpEye 40/40 Series General Technical Specifications**

Spectral response	Infrared and ultraviolet bands
Response time	Varies according to model, typically under 5 seconds
Field of view	Varies according to model, up to 100 degrees
Output	4-20 mA, relays, communication
Enclosure	Stainless steel 316 or aluminum polyurethane painted
Operating voltage	18-32 Vdc
Maximum power rating	9.6 W
Relay contacts	2A/30 Vdc
Over voltage category	2
Relative humidity	Non-condensing relative humidity up to 100%



**⚠ CAUTION**

If the product is used outside of specified limits, this voids the product certification, and our company is not responsible for any incurred warranty expense.

Do not open this product, except for the terminal compartment as listed in this document, under any circumstances.

The detector is not field-repairable. Any attempt to modify or repair the internal circuits or change their settings will impair the system's performance and void the product warranty.

Opening the attachment screws to dismantle the front part of the detector from remaining parts is restricted and voids the product warranty.

**Introduction**  
December 2021

**Reference Manual**  
00909-0100-4975

---

## 2 Installation

### 2.1 Installation guidelines

Installation should comply with the National Fire Protection Association (NFPA) 72E or any other local and international regulations and standards, as applicable to flame detectors and installation of Ex approved products. To ensure optimal performance and efficient installation, consider the following guidelines.

#### Sensitivity

To determine the level of sensitivity, consider the following:

- Size of fire at the required distance to be detected
- Type of flammable materials
- Proximity to false alarm sources

#### Wiring

The wire gauge must be designed according to the distance from the detector to the controller and the number of detectors on the same power line.

To fully comply with EMC directive and protect against interference caused by RFI and EMI, the cable to the detector must be shielded and the detector must be grounded. The shield should be grounded at the detector end.

#### Spacing and location

The number of detectors and their locations in the protected area are determined by:

- Size of the protected area
- Sensitivity of the detectors
- Obstructed lines of sight
- Cone of view of the detectors

#### Environment

Dust, snow, or rain can reduce the detector's sensitivity and require more maintenance activities.

The presence of high intensity emission sources may affect sensitivity.

### 2.2 Preparation for use

The installation sequence may vary according to the physical structure of the site.

---

#### Note

Installation steps are also detailed in the Quick Start Guide supplied with the detector.

---

The following tools are required for installation. These are standard tools and are not supplied with the detector.

**Table 2-1: Required tools**

Tool	Function
Hex key 1.5 mm	Fasten back cover security screw.
Hex key 6 mm	Adjust the tilt mount.
Hex key 10 mm	Affix the detector to the tilt mount.
Hex key 1/8-in	Attach protective cover to detector.
Flat screwdriver 6 mm	Connect ground terminal.
Flat screwdriver 2.5 mm	Connect wires to the terminal blocks.
Hex key 3/8-in	Stop plug 3/4-in NPT.
Open wrench 28 mm	Stop plug M25 only.

## 2.2.1 Field of view

**Figure 2-1: Horizontal field of view for SharpEye 40/40C-I, C-LB, C-L4B, D-I, D-LB, and D-L4B**

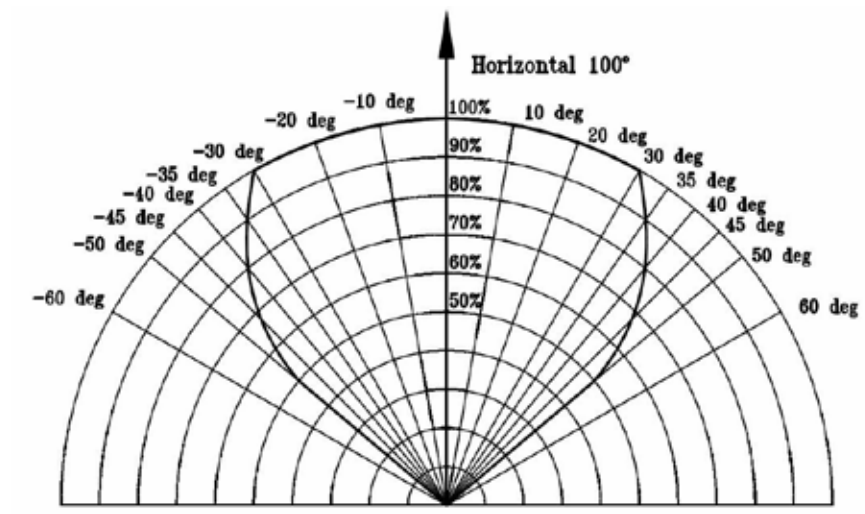
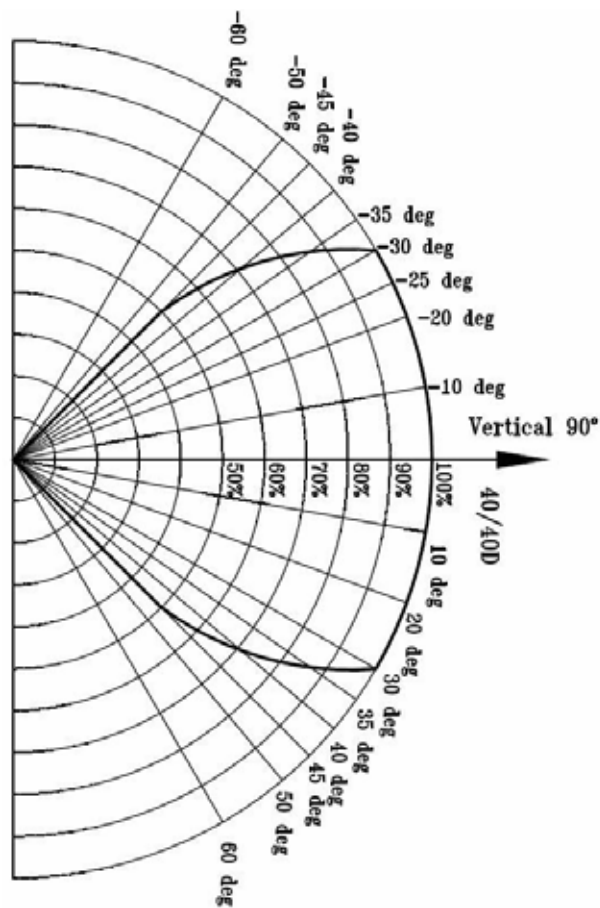

Figure 2-2: Vertical Field of View for SharpEye 40/40C-I, C-LB, C-L4B, D-I, D-LB, and D-L4B



- +50° (down)
- -45° (up)

### Gasoline

For SharpEye 40/40C-M and D-M

- Horizontal: 80°
- Vertical: 80°

Figure 2-3: Vertical and horizontal field of view for gasoline

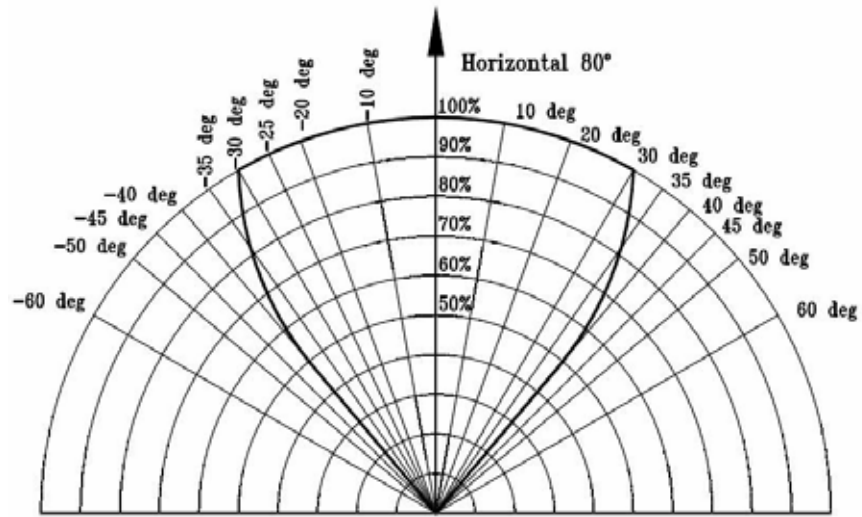

### Hydrogen

For SharpEye 40/40C-M and D-M

- Horizontal: 90°
- Vertical: 90°

Figure 2-4: Horizontal field of view for hydrogen

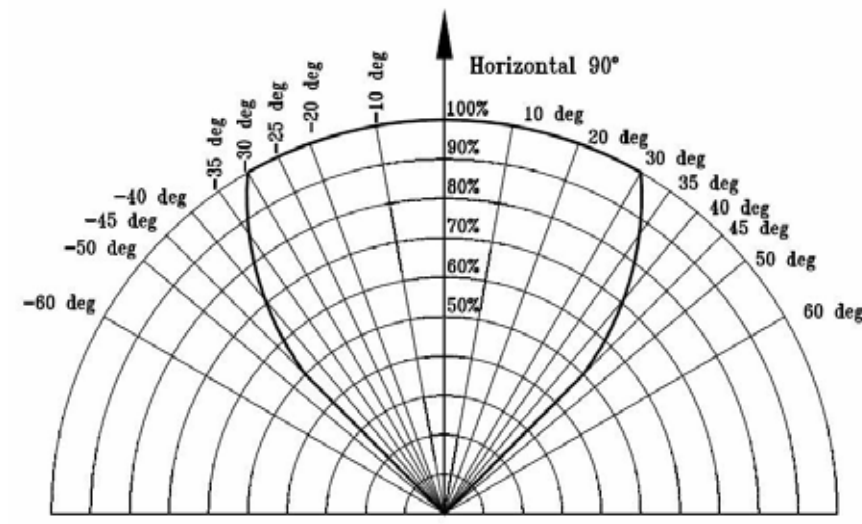
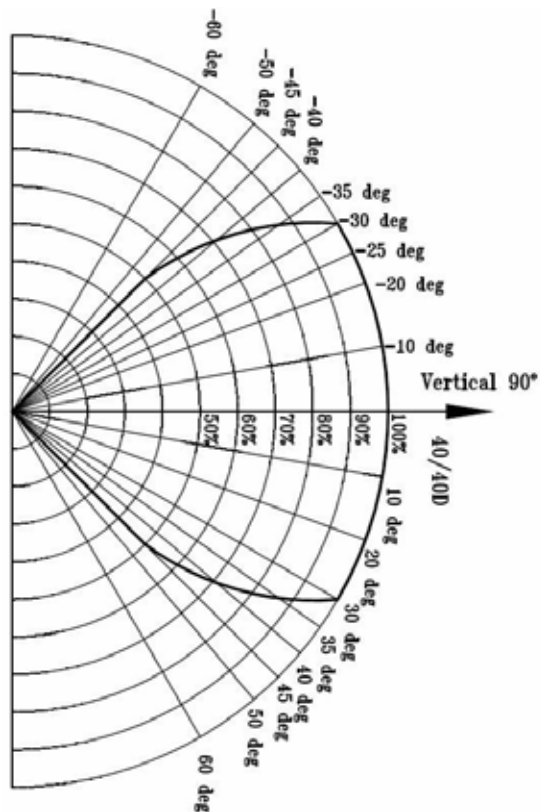

Figure 2-5: Vertical field of view for hydrogen



## 2.3 Attach detector to tilt mount

### Procedure

1. Unpack the detector.
2. Insert location pins on the tilt mount into the openings on detector housing.



3. Thread the holding screw and tighten it.

---

**Note**

To change the detector field of view, release the horizontal and vertical locking screws.

---

4. Point the detector toward the protected area and ensure the view of the area is unobstructed.
5. Secure the detector in that position by tightening the locking screws on the tilt mount.  
The detector is now correctly located, aligned, and ready to be connected to the system.

## 2.4 Open the back cover

### Procedure

1. Loosen the back cover security screw.



- A. Back cover security screw  
B. Protective plug
- 

2. Unscrew the back cover.

**Note**

The back cover is attached by a security cable.

---

3. Remove the protective plug.

## 2.5 Wire terminals and ground cable

### ⚠ CAUTION

Improper wiring may damage the detector.

---



**Procedure**

1. Connect the terminals according to [Table 2-2](#).  
The terminal details are also on the inside back cover.

**Figure 2-6: Terminal box**

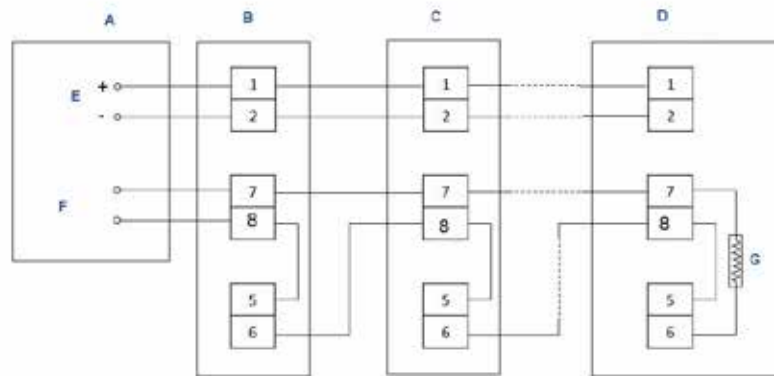

**Table 2-2: Terminal box**

Terminal	Function
T1	24 Vdc (+)
T2	24 Vdc (-)
T3	External built-in test (BIT) switch
T4	Fault relay - normally open
T5	Fault relay
T6	Fault relay - normally closed
T7	Alarm relay - normally open
T8	Alarm relay
T9	Alarm relay - normally closed
T10	0-20 mA (+)
T11	0-20 mA (-)
T12	Alarm output (40/40D models)
T13	RS485 (+)
T14	RS485 (-)
T15	Accessory relay - normally open
T16	Accessory relay
T17	Accessory relay - normally closed

2. Use [Figure 2-7](#), [Figure 2-8](#), [Figure 2-9](#), and [Figure 2-10](#) for typical wiring configurations.

Figure 2-7: Typical wiring for four-wire controllers



- A. Controller
- B. First detector
- C. Second detector
- D. Last detector
- E. Power supply
- F. Alarm loop
- G. End of line

Figure 2-8: Non-isolated sink (three wires)

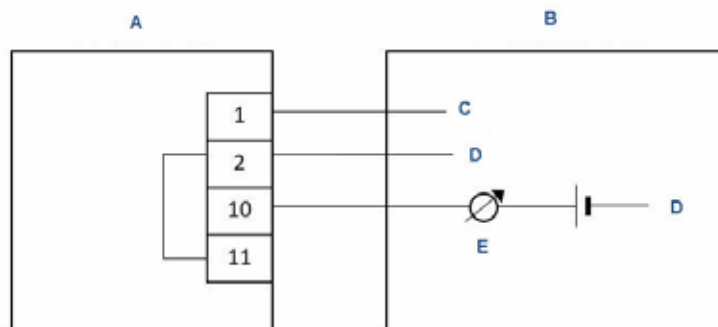

- A. Detector
- B. Controller
- C. Input power: 18 to 32 Vdc
- D. Return
- E. 0-20 mA meter

Figure 2-9: Sink four-wire

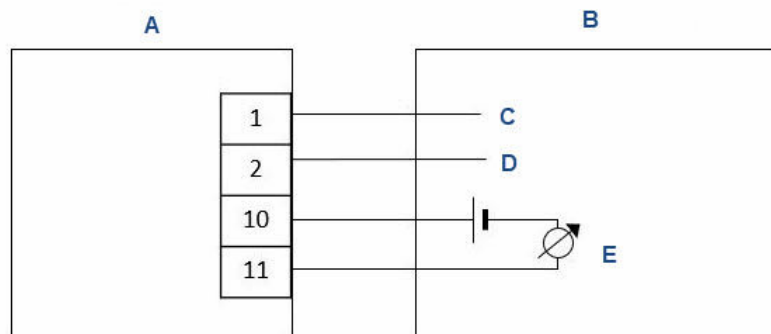

- A. Detector
- B. Controller
- C. Input power: 18 to 32 Vdc
- D. Return
- E. 0-20 mA meter

Figure 2-10: Source three-wire

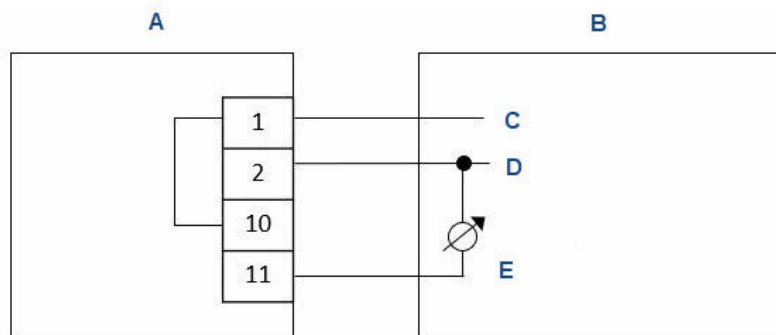

- A. Detector
- B. Controller
- C. Input power: 18-32 Vdc
- D. Return
- E. 0-20 mA meter

**Note**

For additional configuration options, please refer to the [Spectrex SharpEye 40/40C and D Series Flame Detectors Modbus® Manager Manual](#).

3. Check the wires for secure mechanical connection and press them neatly against the terminal to prevent them from interfering while closing the back cover.

4. Close the terminal compartment by screwing the back cover on to the housing.
5. Tighten the back cover security screw.

Figure 2-11: Closing security screw



- A. Back cover security screw
- B. Ground cable connection point

6. Connect the ground cable.

**⚠ WARNING**

The terminal temperature may be higher than 185 °F (85 °C).

**⚠ CAUTION**

To comply with EMC directive 2014/30/EU and protect against interference caused by radio frequency interference (RFI) and electromagnetic interference (EMI), shield the cable to the detector and ground the detector. Ground the shield at the detector end.

## 2.6 Install the protective cover

**⚠ CAUTION**

Always install the protective cover with the detector.

The protective cover is available in ABS plastic or stainless steel.

Table 2-3: Protective cover

Material	Part number
ABS plastic	00975-9000-0020
Stainless steel	00975-9000-0021

#### Procedure

1. Place the protective cover on top of the detector.



2. Secure the protective cover by tightening the screw.

---

**Note**

When installing the stainless steel protective cover, the same installation instructions apply.

---

## 2.7 Aim the detector

Aim the detector toward the center of the detection zone and make sure you have a completely unobstructed view of the protected area.

Emerson recommends positioning the detector tilted down at a 45° angle to maximize coverage and prevent accumulation of dust and dirt.

Do not begin installation until all conceivable considerations regarding detection location have been taken into account.

## 2.8 Changing default detector settings

The Main settings that can be modified using the Modbus® Manager or HART® communication include:

- Sensitivity
- Response time
- Heated optics functionality
- Alarm delay
- Accessory relay options

- Alarm latch
- Field of view integrity indication

Refer to the [Spectrex SharpEye 40/40C and D Series Flame Detectors Modbus Manager Manual](#) or the [Spectrex SharpEye 40/40C and D Series Flame Detectors HART Manual](#) for instructions on changing these settings.

**Installation**  
December 2021

**Reference Manual**  
00909-0100-4975

---



## 3 Operation

### 3.1 Power up the detector

#### Procedure

After connecting the detector to power, wait up to 60 seconds for the detector to completed the initial start-up procedure.

#### Note

Turning on the detector initiates the following sequence of events:

- a. The yellow light-emitting diode (LED) flashes at 4 Hz.
- b. The built-in test (BIT) is executed.
- c. BIT completes.
- d. Detector enters Normal mode, indicated by:
  - Flashing green LED at 1 Hz.
  - Fault relay contacts closing.
  - mA output is 4 mA (for models featuring analog [voltage] output, this will be 2 V).

### 3.2 Testing procedures

This section describes the explosion proof testing procedure using the Spectrex™ explosion proof FS flame simulator series. The detector can also be tested using the Manual BIT.

Table 3-1: Flame Simulator Compatibility

Spectrex model flame simulator	Suitable with detectors
FS-1100	Spectrex 40/40C-I and 40/40D-1
FS-1200	Spectrex 40/40C-LB, 40/40C-L4B, 40/40D-LB, and 40/40D-L4B
FS-1400	Spectrex 40/40C-M and 40/40D-M

To perform a flame simulator test:

1. Power up the system and wait for up to 60 seconds for the detector to return to normal status.  
The **Power** LED turns on.
2. Ensure all indicators show normal (see [Power up the detector](#)).

For full instructions on operating a flame simulator test, see the relevant reference manual.

**Operation**  
December 2021

**Reference Manual**  
00909-0100-4975

**Table 3-2: Flame Simulator Reference Manuals**

<b>Flame simulator</b>	<b>Reference manual</b>
Spectrex FS-1100	TM380002
Spectrex FS-1200	TM380102
Spectrex FS-1400	TM380302

## 4 Initial setup

### 4.1 Continuous feature test

The detector is supplied with default settings, including a continuous feature test.

To change these settings, refer to the [Spectrex SharpEye 40/40C and D Series Flame Detectors Modbus® Manager Manual](#).

During normal operation, the detector tests itself continuously and indicates a fault if a failure is found. This type of test complies with SIL-3 requirements.

The detector continuously tests:

- Input voltage level
- All internal regulator voltage level
- Voltage level status of sensor and sensor circuitry for noise or disconnection in the electronic circuitry
- 0-20 mA level output
- Relays and heater operation
- Processor watch dog
- Software
- Memory
- Oscillator frequency

### 4.2 Response to fault indication

If a failure is found, the detector indicates by:

- Light-emitting diode (LED): yellow flashes (4 Hz)
- Fault relay opens
- 0-20 mA: 1 mA default
- Analog voltage output: 0 V output (SharpEye 40/40D models only)

The fault indications remain until the detector is turned off. The fault indications return if the fault is still found when power is restored.

### 4.3 Built-in-test (BIT)

The detector's BIT checks the following:

- Sensors
- Window cleanliness

- Electronic circuitry

The detector can be set to perform the BIT in the following modes:

- Automatically and manually
- Manually only

#### **BIT operation**

The BIT is intended to check optical integrity and electronic circuitry. The detector's status remains unchanged if the result of a BIT is the same as the current status (Normal or BIT Fault). The detector's status changes if the BIT differs from the current status.

---

#### **Note**

In BIT Fault status, the detector can continue to detect a fire in most cases.

---

#### **Automatic BIT**

The detector automatically performs a BIT every 15 minutes. A successful BIT sequence does not activate any indicator. The BIT interval can be modified if required by the customer using the RS-485 Modbus<sup>®</sup> Manager or HART<sup>®</sup> communicator. In case of a BIT fault, this sequence continues until a successful BIT occurs, when the detector resumes normal operation.

- As result of **successful** automatic/manual BIT, the fault relay remains **energized**.
- As result of **unsuccessful** automatic/manual BIT, the fault relay **de-energizes**.

#### **Manual BIT**

You can initiate manual BIT using the Modbus<sup>®</sup> Manager or HART<sup>®</sup> communicator. Connecting terminal 3 to ground also initiates manual BIT. Alarm duration during manual BIT is configurable using the Modbus Manager or HART communicator.

## 5 Maintenance

### 5.1 Keeping maintenance records

Record all maintenance operations performed on a detector in accordance with site guidance and requirements.

### 5.2 Clean the detector

#### Procedure

1. Disconnect power from the flame detector.
2. Wipe the detector housing with clean water and a damp cloth.

#### **▲ CAUTION**

Do not use a brush or sharp tools.

3. Identify where dust, dirt, or moisture accumulates on the detector window.
  - a) Clean with a soft optical cloth.
  - b) Rinse with clean water.

**Maintenance**  
December 2021

**Reference Manual**  
00909-0100-4975

---

## 6 Troubleshooting

### 6.1 Light-emitting diode (LED) is off, fault relay is open, 0-20 mA shows 0 mA, analog voltage output is 0 V

---

**Note**

Analog voltage output applies to SharpEye 40/40D models only.

---

**Potential cause**

No power to the unit.

**Recommended actions**

1. Check that the operating voltage is correct, according to [Electrical specifications](#).
2. Check power polarity.
3. Check the terminal wiring.

### 6.2 Light-emitting diode (LED) flashes yellow at 4 Hz, fault relay is open, 0-20 mA shows 1 mA

**Potential cause**

Low voltage.

**Recommended action**

Check that the operating voltage is correct, according to [Electrical specifications](#)

**Potential cause**

Faulty detector.

**Recommended action**

Re-power the detector.

### 6.3 Light-emitting diode (LED) flashes yellow at 4 Hz, relay is open, 0-20 mA shows 2 mA

**Potential cause**

Built-in test (BIT) fault.

**Recommended action**

Ensure the detector window and reflector mirror are clean.

**Potential cause**

Faulty detector.

**Recommended action**

Re-power the detector.

## 6.4 **Light-emitting diode (LED) constantly red, alarm relay energized, 0-20 mA indicates alarm**

**Potential cause**

Existing alarm condition.

**Recommended action**

Check cause of alarm.

**Potential cause**

Alarm latched.

**Recommended action**

Ensure the alarm latch is not enabled in the detector settings.

**Potential cause**

Faulty detector.

**Recommended action**

Re-power the detector.

## 6.5 **No HART<sup>®</sup> communication, 0-20 mA shows 0 mA**

**Potential**

No HART is available at 0 mA level.

**Recommended action**

For Fault mode, the default indication is 1 mA. Configure this to 0 mA.

Emerson does not recommend this when using a HART connection in order to preserve the HART communication.



## 7 Specifications

### 7.1 Technical specifications

#### Spectral response

<b>SharpEye 40/40C-I</b>	Four infrared (IR) bands between 4 $\mu\text{m}$ and 5 $\mu\text{m}$
<b>SharpEye 40/40C-M</b>	Four IR bands between 2 $\mu\text{m}$ and 5 $\mu\text{m}$
<b>SharpEye 40/40C-LB</b>	Ultraviolet (UV): 0.185 - 0.260 $\mu\text{m}$ IR: 2.5-3.0 $\mu\text{m}$
<b>SharpEye 40/40C-L4B</b>	UV: 0.185 - 0.260 $\mu\text{m}$ IR: 4.3 – 4.8 $\mu\text{m}$
<b>SharpEye 40/40D-I</b>	Four infrared (IR) bands between 4 $\mu\text{m}$ and 5 $\mu\text{m}$
<b>SharpEye 40/40D-M</b>	Four IR bands between 2 $\mu\text{m}$ and 5 $\mu\text{m}$
<b>SharpEye 40/40D-LB</b>	Ultraviolet (UV): 0.185 - 0.260 $\mu\text{m}$ IR: 2.5-3.0 $\mu\text{m}$
<b>SharpEye 40/40D-L4B</b>	UV: 0.185 - 0.260 $\mu\text{m}$ IR: 4.3 – 4.8 $\mu\text{m}$

#### Detection range per fuel (ft./m)

##### Note

The ranges shown are at highest sensitivity setting for 1 ft<sup>2</sup> (0.1 m<sup>2</sup>) pan fire.

Table 7-1: SharpEye 40/40C Models

Fuel	40/40C-I	40/40C-M	40/40C-LB	40/40C-L4B
Gasoline	215 ft (65 m)		50 ft (15 m)	93 ft (28 m)
N-Heptane	215 ft (65 m)		50 ft (15 m)	93 ft (28 m)
Diesel fuel	150 ft (45 m)		37 ft (11 m)	70 ft (21 m)
Kerosene	150 ft (45 m)		37 ft (11 m)	70 ft (21 m)
Alcohol 95%	135 ft (40 m)		30 ft (9 m)	57 ft (17 m)
IPA	135 ft (40 m)		37 ft (11 m)	70 ft (21 m)
Methanol	135 ft (40 m)		30 ft (9 m)	57 ft (17 m)
Methane	150 ft (45 m)		30 ft (9 m)	60 ft (18 m)
LPG	150 ft (45 m)		30 ft (9 m)	60 ft (18 m)
Polypropylene	115 ft (35 m)		30 ft (9 m)	60 ft (18 m)
Paper	82.0 ft (25 m)		16.4 ft (5 m)	33 ft (10 m)
Hydrogen	N/A	118.1 ft (36 m)	37 ft (11 m)	N/A

Table 7-1: SharpEye 40/40C Models (continued)

Fuel	40/40C-I	40/40C-M	40/40C-LB	40/40C-L4B
Magnesium alloy <sup>(1)</sup>	N/A		16.4 ft (5 m)	33 ft (10 m)
Gun powder	141.1 ft (43 m)		32.8 ft (10 m)	91.9 ft (28 m)
Fireworks	23.0 ft (7 m)		5.25 ft (1.6 m)	9.8 ft (3 m)
Cooking oil	147.6 ft (45 m)		37 ft (11 m)	70 ft (21 m)
Mineral oil: 20w50	150 ft (45 m)		37 ft (11 m)	70 ft (21 m)
Wood	82 ft (25 m)		16 ft (5 m)	33 ft (10 m)
Ethylene glycol	118 ft (36 m)		12 ft (3.66 m)	23 ft (7 m)
Butyl acrylate	117 ft (36 m)		37 ft (11 m)	70 ft (21 m)
Vinyl acetate	117 ft (36 m)		37 ft (11 m)	70 ft (21 m)
Flammable adhesive	150 ft (45 m)		37 ft (11 m)	70 ft (21 m)
Solvents	117 ft (36 m)		37 ft (11 m)	70 ft (21 m)
Oil paint	150 ft (45 m)		37 ft (11 m)	70 ft (21 m)
Jet fuel JP5	150 ft (45 m)		37 ft (11 m)	70 ft (21 m)
Jet fuel A1	150 ft (45 m)		37 ft (11 m)	70 ft (21 m)
Battery <sup>(2)</sup>	200 ft (61 m)		39 ft (12 m)	75 ft (23 m)

(1) Contact Spectrex representative for guidance on detecting Magnesium alloy.

(2) One battery cell.

Table 7-2: SharpEye 40/40D Models

Fuel	SharpEye 40/40D-I	SharpEye 40/40D-M	SharpEye 40/40D-LB	SharpEye 40/40D-L4B
Gasoline	300 ft (90 m)		93 ft (28 m)	
N-Heptane	300 ft (90 m)		93 ft (28 m)	
Diesel fuel	207 ft (63 m)		70 ft (21 m)	
Kerosene	207 ft (63 m)		70 ft (21 m)	
Alcohol 95%	185 ft (55 m)		57 ft (17 m)	
Isopropyl alcohol (IPA)	185 ft (55 m)		70 ft (21 m)	
Methanol	185 ft (55 m)		57 ft (17 m)	
Methane	207 ft (63 m)		60 ft (18 m)	
Liquified petroleum gas (LPG)	207 ft (63 m)		60 ft (18 m)	
Polypropylene	160 ft (49 m)		60 ft (18 m)	

**Table 7-2: SharpEye 40/40D Models (continued)**

Fuel	SharpEye 40/40D-I	SharpEye 40/40D-M	SharpEye 40/40D-LB	SharpEye 40/40D-L4B
Paper	112 ft (34 m)		10 ft (3 m)	
Hydrogen	N/A	164 ft (50 m)	70 ft (21 m)	N/A
Magnesium alloy <sup>(1)</sup>	N/A		33 ft (10 m)	
Gun powder	197 ft (60 m)		66 ft (20 m)	93 ft (28 m)
Fireworks	33 ft (10 m)		10 ft (3 m)	
Cooking oil	207 ft (63 m)		70 ft (21 m)	
Mineral oil: 20 w 50	207 ft (63 m)		70 ft (21 m)	
Wood	112 ft (34 m)		33 ft (10 m)	
Ethylene glycol	164 ft (50 m)		23 ft (7 m)	
Butyl acrylate	246 ft (75 m)		70 ft (21 m)	
Vinyl acetate	246 ft (75 m)		70 ft (21 m)	
Flammable adhesive	207 ft (63 m)		70 ft (21 m)	
Solvents	246 ft (75 m)		70 ft (21 m)	
Oil paint	207 ft (63 m)		70 ft (21 m)	
Jet fuel JP5	207 ft (63 m)		70 ft (21 m)	
Jet fuel A1	207 ft (63 m)		70 ft (21 m)	
Battery <sup>(2)</sup>	279 ft (85 m)		75 ft (23 m)	

(1) Contact Emerson representative for guidance on detecting magnesium alloy.

(2) One battery cell.

**Standard response time**
**Table 7-3: SharpEye 40/40C Models**

Spectrex 40/40C-I	Spectrex 40/40C-M	Spectrex 40/40C-LB	Spectrex 40/40C-L4B
Typically <5 sec			

**Table 7-4: SharpEye 40/40D Models**

SharpEye 40/40D-I	SharpEye 40/40D-M	SharpEye 40/40D-LB	SharpEye 40/40D-L4B
Typically <2 sec at 131 ft (40 m) 10 sec at 300 ft (90 m)		Typically 5 sec at 93 ft (28 m)	

**Ultra fast response time**
**Table 7-5: SharpEye 40/40C Models**

Spectrex 40/40C-I	Spectrex 40/40C-M	Spectrex 40/40C-LB	Spectrex 40/40C-L4B
N/A			

**Table 7-6: SharpEye 40/40D Models**

SharpEye 40/40D-I	SharpEye 40/40D-M	SharpEye 40/40D-LB	SharpEye 40/40D-L4B
Typically <1 sec at 100 ft (30 m)		20 msec for flash fire at 10 ft (3 m)	

**High speed response time**
**Table 7-7: SharpEye 40/40C Models**

Spectrex 40/40C-I	Spectrex 40/40C-M	Spectrex 40/40C-LB	Spectrex 40/40C-L4B
N/A			

**Table 7-8: SharpEye 40/40D Models**

SharpEye 40/40D-I	SharpEye 40/40D-M	SharpEye 40/40D-LB	SharpEye 40/40D-L4B
50 msec for 1 ft <sup>2</sup> (0.1 m <sup>2</sup> ) diameter sphere LPG-air mixture explosion at 66 ft (20 m)		50 msec for 1 ft <sup>2</sup> (0.1 m <sup>2</sup> ) diameter sphere LPG-air mixture explosion at 33 ft (10 m)	

**Sensitivity ranges**
**Note**

 All distances relate to detection of a 1 ft<sup>2</sup> (0.1 m<sup>2</sup>) n-heptane fire

**Table 7-9: SharpEye 40/40C Models**

Spectrex 40/40C-I	Spectrex 40/40C-M	Spectrex 40/40C-LB	Spectrex 40/40C-L4B
Five ranges: <ul style="list-style-type: none"> <li>• 10 ft (3 m)</li> <li>• 50 ft (15 m)</li> <li>• 100 ft (30 m)</li> <li>• 150 ft (45 m)</li> <li>• 215 ft (65 m)</li> </ul>		Two ranges: <ul style="list-style-type: none"> <li>• 10 ft (3 m)</li> <li>• 50 ft (15 m)</li> </ul>	Three ranges: <ul style="list-style-type: none"> <li>• 10 ft (3 m)</li> <li>• 50 ft (15 m)</li> <li>• 92 ft (28 m)</li> </ul>

**Table 7-10: SharpEye 40/40D Models**

SharpEye 40/40D-I	SharpEye 40/40D-M	SharpEye 40/40D-LB	SharpEye 40/40D-L4B
Six ranges: <ul style="list-style-type: none"> <li>• 10 ft (3 m)</li> <li>• 50 ft (15 m)</li> <li>• 100 ft (30 m)</li> <li>• 150 ft (45 m)</li> <li>• 215 ft (65 m)</li> <li>• 300 ft (90 m)</li> </ul>		Three ranges: <ul style="list-style-type: none"> <li>• 10 ft (3 m)</li> <li>• 50 ft (15 m)</li> <li>• 92 ft (28 m)</li> </ul>	

**Field of view**
**Table 7-11: SharpEye 40/40C Models**

Spectrex 40/40C-I	Spectrex 40/40C-M	Spectrex 40/40C-LB	Spectrex 40/40C-L4B
H: 100° V: 95°	Hydrogen: H: 90° V: 90°	H: 100° V: 95°	
H: 100° V: 95°	Other fuels: H: 80° V: 80°	H: 100° V: 95°	

**Table 7-12: SharpEye 40/40D Models**

SharpEye 40/40D-I	SharpEye 40/40D-M	SharpEye 40/40D-LB	SharpEye 40/40D-L4B
Horizontal: 100° Vertical: 95°	Hydrogen Horizontal: 90° Vertical: 90°	Horizontal: 100° Vertical: 95°	
	Other fuels Horizontal: 80° Vertical: 80°		

**Temperature range (operating and storage)**
**Table 7-13: SharpEye 40/40C Models**

Spectrex 40/40C-I	Spectrex 40/40C-M	Spectrex 40/40C-LB	Spectrex 40/40C-L4B
-40 °F (-40 °C) to 167 °F (75 °C)			

**Table 7-14: SharpEye 40/40D Models**

SharpEye 40/40D-I	SharpEye 40/40D-M	SharpEye 40/40D-LB	SharpEye 40/40D-L4B
-76 °F (-60 °C) to 185 °F (85 °C)			

**Humidity**

Non-condensing relative humidity up to 100 percent.

## 7.2 Electrical specifications

The electrical specifications apply to all models unless stated otherwise.

<b>Operating voltage</b>	24 Vdc nominal (18-32 Vdc)
<b>Power consumption</b>	Standby: Max. 3 W (8 W with heated window) Alarm: Max. 4.2 W (9.6 W with heated window)
<b>Cable entries</b>	2 x ¾-in - 14 NPT conduits or 2 x M25 x 1.5 mm International Organization for Standardization (ISO)
<b>Electrical input protection</b>	According to EN 50130
<b>Electromagnetic capability</b>	Electromagnetic interference/Radio frequency interference (EMI/RFI) protected to EN61000-6-3 and EN 50130
<b>Electrical interface</b>	The detector includes 17 terminals, one wiring option.

### Electrical input protection

The input circuit is protected against voltage-reversed polarity, voltage transients, surges, and spikes according to EN 54-10.

### Outputs

<b>Relays</b>	Alarm, fault, and auxiliary SPST volt-free contacts rated 2A at 30 Vdc	
<b>Analog</b>	5 V at detection, 0 V at fault, 2 V at normal	
<b>0-20 mA (stepped)</b>	<b>SharpEye 40/40C Models</b>	Fault: 0 +1 mA BIT fault: 2mA ± 0.3mA Normal: 4mA ± 0.3mA Warning: 16mA ± 0.3mA Alarm: 20mA ± 0.3mA
	<b>SharpEye 40/40D Models</b>	Fault: 0 +1 mA Built-in test (BIT) Fault: 2 mA ± 0.3 mA Normal: 4 mA ± 0.3 mA Warning: 16 mA ± 0.3 mA Alarm: 20 mA ± 0.3 mA

### Heated optics

The front window can be heated to improve performance in ice, condensation, and snow conditions. The heater increases the temperature of the optical surface by 5 °C to 25 °C above the ambient temperature<sup>(1)</sup>. The heated optics can be configured in three ways:

<b>Off</b>	Optics are not heated
------------	-----------------------

(1) SharpEye 40/40D models have a low power heater option

- On** Optics are continuously heated
- Auto (default)** Operated only when the change of temperature requires the heating

**Note**

In Auto mode, the starting heat temperature can be defined between 32 °F (0 °C) and 95 °F (35 °C). The detector stops heating the window when the temperature is 15 °C above the start temperature.

## 7.3 Mechanical specifications

### Enclosure options

- SharpEye 40/40C Models** Heavy duty copper free aluminum (less than 1%), polyurethane painted
- SharpEye 40/40D Models** Stainless steel 316 with electropolish finish  
Heavy duty copper free aluminum (less than one percent), polyurethane painted

### Tilt mount

Stainless steel 316 with electropolish finish

### Detector dimensions

4 in (100.6 mm) x 4.6 in (117 mm) x 6.18 in (155 mm)

### Weight

- SharpEye 40/40C Models** Detector: 2.8 lb (1.3 kg)  
Tilt mount 2.5 lb (1.13 kg)
- SharpEye 40/40D Models** Stainless steel detector: 6.3 lb (2.9 kg)  
Aluminum detector: 2.8 lb (1.3 kg)  
Tilt mount 2.5 lb (1.13 kg)

### Environmental standards

DNV 2-4<sup>(2)</sup>

### Water and dust

IP66 and IP68 per EN 60529

<sup>(2)</sup> SharpEye 40/40D Models only

**Specifications**  
December 2021

**Reference Manual**  
00909-0100-4975

---



## A Reference data

### A.1 Ordering information, specifications, and dimensional drawings

To view current SharpEye 40/40 Series ordering information, specifications, and dimensional drawings, follow these steps:

#### Procedure

1. Go to [Spectrex.net/en-us/flame-gas-detectors-flame-detectors-40-40-series](https://spectrex.net/en-us/flame-gas-detectors-flame-detectors-40-40-series).
2. Select the appropriate product.
3. Scroll down to **Documents and Drawings**.
4. Select **DATA SHEETS & BULLETINS**
5. Select the appropriate Product Data Sheet.

### A.2 Product certifications and installation drawings

To view current SharpEye 40/40 Series product certifications and installation drawings, follow these steps:

#### Procedure

1. Go to [Spectrex.net/en-us/flame-gas-detectors-flame-detectors-40-40-series](https://spectrex.net/en-us/flame-gas-detectors-flame-detectors-40-40-series).
2. Select the appropriate product.
3. Scroll down to **Documents and Drawings**.
4. Select **CERTIFICATES & APPROVALS**
5. Select the appropriate document.

**Reference data**

December 2021

**Reference Manual**

00909-0100-4975

---

## B FM fuel test responses

Results of the FM fuel tests are as follows:

Table B-1: SharpEye 40/40C Models

Fuel	SharpEye 40/40C-I	SharpEye 40/40C-M	SharpEye 40/40 C-LB	SharpEye 40/40 C-L4B
Gasoline <sup>(1)</sup>	213 ft (65 m)		49 ft (15 m)	92 ft (28 m)
N-Heptane <sup>(1)</sup>	213 ft (65 m)		49 ft (15 m)	92 ft (28 m)
Diesel fuel <sup>(1)</sup>	148 ft (45 m)		36 ft (11 m)	69 ft (21 m)
JP5 <sup>(1)</sup>	148 ft (45 m)		36 ft (11 m)	69 ft (21 m)
Kerosene <sup>(1)</sup>	148 ft (45 m)		36 ft (11 m)	69 ft (21 m)
Alcohol 95% <sup>(1)</sup>	131 ft (40 m)		30 ft (9 m)	56 ft (17 m)
IPA <sup>(1)</sup>	131 ft (40 m)		36 ft (11 m)	69 ft (21 m)
Methanol <sup>(1)</sup>	131 ft (40 m)		30 ft (9 m)	56 ft (17 m)
Methane <sup>(2)</sup>	148 ft (45 m)		33 ft (10 m)	59 ft (18 m)
LPG <sup>(2)</sup>	148 ft (45 m)		33 ft (10 m)	59 ft (18 m)
Polypropylene <sup>(1)</sup>	115 ft (35 m)		30 ft (9 m)	59 ft (18 m)
Paper <sup>(1)</sup>	82 ft (25 m)		16 ft (5 m)	33 ft (10 m)
Hydrogen <sup>(2)</sup>	N/A	118 ft (36 m)	36 ft (11 m)	N/A
Magnesium alloy <sup>(3)</sup>	N/A		16 ft (5 m)	33 ft (10 m)
Gun powder <sup>(4)</sup>	141 ft (43 m)		33 ft (10 m)	92 ft (28 m)
Fireworks <sup>(5)</sup>	23 ft (7 m)		5 ft (1.52 m)	10 ft (3 m)
Cooking oil <sup>(1)</sup>	148 ft (45 m)		36 ft (11 m)	69 ft (21 m)
Mineral oil: 20w50 <sup>(1)</sup>	148 ft (45 m)		36 ft (11 m)	69 ft (21 m)
Wood <sup>(1)</sup>	82 ft (25 m)		16 ft (5 m)	33 ft (10 m)
Ethylene glycol <sup>(1)</sup>	118 ft (36 m)		12 ft (4 m)	23 ft (7 m)
Butyl acrylate <sup>(1)</sup>	117 ft (36 m)		36 ft (11 m)	69 ft (21 m)
Vinyl acetate <sup>(1)</sup>	117 ft (36 m)		36 ft (11 m)	69 ft (21 m)
Flammable adhesive <sup>(1)</sup>	148 ft (45 m)		36 ft (11 m)	69 ft (21 m)
Solvents <sup>(1)</sup>	117 ft (36 m)		36 ft (11 m)	69 ft (21 m)
Oil paint <sup>(1)</sup>	148 ft (45 m)		36 ft (11 m)	69 ft (21 m)
JET A1 <sup>(1)</sup>	148 ft (45 m)		36 ft (11 m)	69 ft (21 m)

Table B-1: SharpEye 40/40C Models (continued)

Fuel	SharpEye 40/40C-I	SharpEye 40/40C-M	SharpEye 40/40 C-LB	SharpEye 40/40 C-L4B
Battery <sup>(6)</sup>	200 ft (61 m)		39 ft (12 m)	76 ft (23 m)

- (1) 1 ft<sup>2</sup> (0.1 m<sup>2</sup>) pan fire  
 (2) Plume fire: 2.5 ft (0.75 m) high, 0.8 ft (0.25 m) wide  
 (3) Only for UV detector.  
 (4) 1.5 in<sup>2</sup> (10 cm<sup>2</sup>) pan fire  
 (5) 10 pieces per test.  
 (6) One battery cell.

Table B-2: SharpEye 40/40D Models

Fuel	SharpEye 40/40D-I	SharpEye 40/40D-M	SharpEye 40/40D-LB	SharpEye 40/40D-L4B
Gasoline <sup>(1)</sup>	295 ft (90 m)		92 ft (28 m)	
N-Heptane <sup>(1)</sup>	295 ft (90 m)		92 ft (28 m)	
Diesel fuel <sup>(1)</sup>	207 ft (63 m)		69 ft (21 m)	
JP5 <sup>(1)</sup>	207 ft (63 m)		69 ft (21 m)	
Kerosene <sup>(1)</sup>	207 ft (63 m)		69 ft (21 m)	
Alcohol 95% <sup>(1)</sup>	180 ft (55 m)		56 ft (17 m)	
Isopropyl alcohol <sup>(1)</sup>	180 ft (55 m)		69 ft (21 m)	
Methanol <sup>(1)</sup>	180 ft (55 m)		56 ft (17 m)	
Methane <sup>(2)</sup>	207 ft (63 m)		59 ft (18 m)	
Liquified petroleum gas (LPG) <sup>(1)</sup>	207 ft (63 m)		59 ft (18 m)	
Polypropylene <sup>(1)</sup>	161 ft (49 m)		59 ft (18 m)	
Paper <sup>(1)</sup>	112 ft (34 m)		33 ft (10 m)	
Hydrogen <sup>(1)</sup>	N/A	164 ft (50 m)	69 ft (21 m)	N/A
Magnesium alloy <sup>(3)</sup>	N/A		33 ft (10 m)	
Gun powder <sup>(4)</sup>	197 ft (60 m)		66 ft (20 m)	92 ft (28 m)
Fireworks <sup>(5)</sup>	33 ft (10 m)		10 ft (3 m)	
Cooking oil <sup>(1)</sup>	207 ft (63 m)		69 ft (21 m)	
Mineral oil: 20 w 50 <sup>(1)</sup>	207 ft (63 m)		69 ft (21 m)	
Wood <sup>(1)</sup>	112 ft (34 m)		33 ft (10 m)	
Ethylene glycol <sup>(1)</sup>	164 ft (50 m)		23 ft (7 m)	
Butyl acrylate <sup>(1)</sup>	246 ft (75 m)		69 ft (21 m)	

Table B-2: SharpEye 40/40D Models (continued)

Fuel	SharpEye 40/40D-I	SharpEye 40/40D-M	SharpEye 40/40D-LB	SharpEye 40/40D-L4B
Vinyl acetate <sup>(1)</sup>	246 ft (75 m)		69 ft (21 m)	
Flammable adhesive <sup>(1)</sup>	207 ft (63 m)		69 ft (21 m)	
Solvents <sup>(1)</sup>	246 ft (75 m)		69 ft (21 m)	
Oil paint <sup>(1)</sup>	207 ft (63 m)		69 ft (21 m)	
Jet fuel A1 <sup>(1)</sup>	207 ft (63 m)		69 ft (21 m)	
Battery <sup>(6)</sup>	279 ft (85 m)		76 ft (23 m)	

- (1) 1 ft<sup>2</sup> (0.1 m<sup>2</sup>) pan fire  
 (2) Plume fire: 2.5 ft (0.75 m) high, 0.8 ft (0.25 m) wide  
 (3) Only for ultraviolet (UV) detector.  
 (4) 1.5 in<sup>2</sup> (10 cm<sup>2</sup>) pan fire  
 (5) Ten pieces per test.  
 (6) One battery cell.

**FM fuel test responses**  
December 2021

**Reference Manual**  
00909-0100-4975

---

## C Immunity to false alarm sources

Table C-1: Immunity to false alarm sources

IAD: Immunity at any distance

Radiation source	Immunity distance			
	SharpEye 40/40C-I and D-I	SharpEye 40/40C-M and D-M	SharpEye 40/40C-LB and D-LB	SharpEye 40/40C-L4B and D-L4B
Indirect or reflected sunlight	IAD	IAD	IAD	IAD
Vehicle headlights (low beam) conforming to MS53023	IAD	IAD	IAD	IAD
Incandescent frosted glass light, 300 W	IAD	IAD	IAD	IAD
Fluorescent light with white enamel reflector, standard office or shop, 80 W (or two 40 W)	IAD	IAD	IAD	IAD
Electric arc (15/32-in (12 mm)) gap at 4000 Vac, 60 Hz	IAD	IAD	IAD	IAD
Arc welding (5/16-in (6 mm)) rod, 210 A	See <a href="#">Table C-2</a> .	See <a href="#">Table C-2</a> .	See <a href="#">Table C-2</a> .	See <a href="#">Table C-2</a> .
Ambient light extremes (darkness to bright light with snow, water, rain, desert glare, or fog)	IAD	IAD	IAD	IAD
Bright colored clothing, including red and safety orange	IAD	IAD	IAD	IAD
Electronic flash (180 W seconds minimum output)	IAD	IAD	IAD	IAD
Movie light, 625 W quartz DWY lamp (Sylvania S.G. 55 or equivalent)	>6.5 ft (2 m)	>6.5 ft (2 m)	>13 ft (4 m)	>3 ft (1 m)
Blue green dome light conforming to M251073	IAD	IAD	IAD	IAD
Flashlight (MX 991/U)	IAD	IAD	IAD	IAD
Radiation heater, 3000 W	>3 ft (1 m)	>3 ft (1 m)	IAD	IAD
Radiation heater, 1000 W with fan	IAD	IAD	IAD	IAD
Quartz lamp (1000 W)	>3 ft (1 m)	>3 ft (1 m)	See <a href="#">Table C-3</a> .	See <a href="#">Table C-3</a> .
Mercury vapor lamp	IAD	IAD	IAD	IAD
Grinding metal	IAD	IAD	IAD	IAD
Lit cigar	>1 ft (0.3 m)	>1 ft (0.3 m)	IAD	IAD
Lit cigarette	>1 ft (0.3 m)	>1 ft (0.3 m)	IAD	IAD
Match, wood, stick, including flare up	>20 ft (6 m)	>10 ft (3 m)	>7 ft (2 m)	>7 ft (2 m)

Table C-1: Immunity to false alarm sources (continued)

Radiation source	Immunity distance			
	SharpEye 40/40C-I and D-I	SharpEye 40/40C-M and D-M	SharpEye 40/40C-LB and D-LB	SharpEye 40/40C-L4B and D-L4B
Vehicle exhaust diesel fume For SharpEye 40/40D-IH only	IAD	IAD	N/A	N/A

Table C-2: Welding immunity distance

Level	Range	Distance
1	>10 ft (3 m)	>1.6 ft (0.5 m)
2	>50 ft (15 m)	>6 ft (2 m)
3	>100 ft (30 m)	>12 ft (4 m)
4	>150 ft (45 m)	>17 ft (6 m)
5	>215 ft (65 m)	>25 ft (7.5 m)
6	>295 ft (90 m)	>33 ft (10 m)

Table C-3: Halogen immunity distance

Sensitivity level	Detection range	Halogen distance			
		SharpEye 40/40C-LB and D-LB		SharpEye 40/40C-L4B and D-L4B	
		750 W	1000 W	750 W	1000 W
1	10 ft (3 m)	>13 ft (4 m)	>15 ft (4.5 m)	>6 ft (2 m)	>8 ft (2.5 m)
2	50 ft (15 m)	>43 ft (13 m)	>50 ft (15 m)	>15 ft (4.5 m)	>16 ft (5 m)
3	93 ft (28 m)	>66 ft (20 m)	>70 ft (21 m)	>27 ft (8 m)	>30 ft (9 m)





For more information: [www.emerson.com](http://www.emerson.com)

©2021 Emerson. All rights reserved.

Spectrex is a mark of one of the Emerson family of companies.  
All other marks are the property of their respective owners.

